

Ferroelectric Liquid Crystal Display

Mitsuhiro Kodon *¹

Keisaku Nonomura *¹

Hirofumi Katsuse *¹

P. A. Gass *²

J. C. Jones *³

A. Graham *³

Syuhji Miyoshi *¹

Michiyuki Sugino *¹

Akira Tagawa *¹

M. J. Towler *²

C. V. Brown *³

M. J. Bradshaw *³

Mitsuhiro Shigeta *¹

Takaji Numao *¹

Yasuhiro Kawabata *¹

E. P. Raynes *²

J. R. Hughes *³

D. G. McDonnell *³

*1 Functional Device Laboratories

*2 Sharp Laboratories of Europe, Ltd. (SLE)

*3 Defense Evaluation and Research Agency (DERA)

Abstract

Key technologies for the τ -Vmin mode FLCs (Ferroelectric Liquid Crystal Displays) were developed. An FLC material with negative dielectric anisotropy was developed, realizing fast line address time of 23 μ sec/line at 25°C. The C2-uniform (C2U) orientation with chevron layer structure was achieved by using an aligning film with medium pretilt angle. High shock stability (20kg/cm²) was achieved by making a spacer wall structure within display. Combining these key technologies with digital gray scale method (2 bits spatial dither and 3 bits temporal dither), a 6"-prototype color FLC with 240x320 dots, 262,000 colors (64 gray levels for each color) was fabricated.

Introduction

Since Clark and Lagerwall ¹⁾ invented the basic principle of ferroelectric liquid crystal displays (FLCs), much effort has been devoted to the development of FLCs, aiming at practical applications. ^{2),3)}

While the conventionally existing LCDs such as STN-LCDs and TFT-LCDs utilize a nematic liquid crystal phase, it is remarked that FLCs utilize a chiral smectic C liquid crystal phase with spontaneous polarization (P_s). In the chiral smectic C phase, liquid crystal molecules have a layer structure in which the mean direction of molecular long axis is tilted against layers. In thin FLC cells, a bistability appears with two bistable states as shown in **Fig.1(a)(b)**. Ferroelectric liquid crystals have a spontaneous polarization (P_s) whose direction is perpendicular to the layer. When the electric field is applied, molecules re-align in a way that the

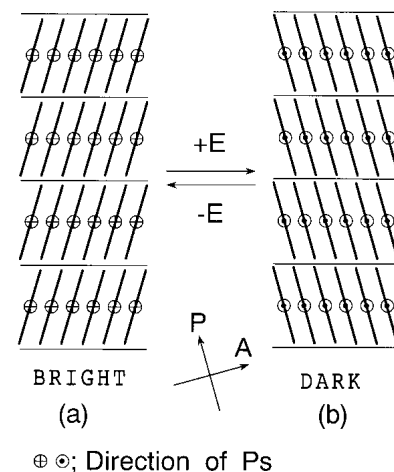

Fig. 1 Principle of FLC.

direction of the spontaneous polarizations is the same as that of the electric field. Combining a pair of polarizers (polarizer and analyzer), FLCs can realize dark and bright states.

Since nematic liquid crystal is paraelectric, the order of response time is usually μsec . On the contrary, FLC shows μsec in its order of response time because of the direct interaction between electric field and P_s . In addition, FLCs have several advantages, such as wide viewing angle due to the in-plane switching (IPS) and memory effect due to the bistability. The combination of fast response time and memory effect allows large-size direct-view simple-multiplexing LCDs with high resolution.

The molecular orientation control is one of the most important key technologies for the development of practical FLCs.^{2),3)} The molecular orientations of FLCs are classified as two layer structures: a bookshelf layer and a chevron layer. The FLC cells with parallel rubbing, in which the rubbing directions of both substrates are the same, have been known to show four orientational states with a chevron layer structure: C1-uniform (C1U), C1-twisted (C1T), C2-uniform (C2U) and C2-twisted (C2T).⁴⁾ Among them, the C1U and C2U orientations are useful for practical applications because of their extinction positions between cross nicols.

Tsuboyama et al.⁵⁾ and Koden et al.⁶⁾ have respectively reported that an alignment film with a high pre-tilt angle (over 15 degrees) induced the selective formation of the C1U orientation and also that the C1U orientation gave a high contrast ratio under simple-multiplexing driving waveforms for FLCs. Using the C1U orientation, Hanyu et al. have developed a 21-inch color FLC (1024 x 1280 dots, contrast ratio of 40:1 and 64 colors).

Recently, Mizutani et al. developed a 15" full-color FLC (768 x 1024 dots, $36\mu\text{sec}/\text{line}$, CR=100:1) with a bookshelf layer structure, realizing full-color images by a combination of 4-bit spatial dither and dither methods.⁸⁾

Furthermore, Koden et al.¹⁰⁾ have reported that the C2U orientation can show a high contrast ratio, fast line address time and wide memory angle if it is combined with the τ -Vmin. The τ -Vmin mode⁹⁾ utilizes the unique response (t) - voltage (V) characteristics of the minimum value, which is observed in FLC materials with large positive dielectric biaxiality (negative dielectric anisotropy). The τ -Vmin mode utilizing the C2U orientation is a promising technology for digital gray scale method with temporal dither because it can realize faster line address time than the C1U orientation and the bookshelf orientation can.

Compared with the existing LCDs, the FLC have received an unfavorable reputation of poor performance in moving picture with gray scale and also in shock stability. In this study, key technologies for the τ -Vmin mode were developed in order to overcome these problems. This paper describes FLC materials that show fast response time for the τ -Vmin mode, the selective

formation of the C2U orientation, the device structure with high shock stability and the digital gray scale driving method, introducing a 6-inch color prototype FLCD which was fabricated by using these key technologies.

1. Key Technologies for the τ -Vmin Mode FLCDs

1.1 Ferroelectric Liquid Crystal Materials

In the τ -Vmin characteristics of FLC materials, the minimum voltage is mentioned as Vmin and the minimum response time as τ min. Low Vmin and fast τ min are required because the Vmin value determines the drive voltage and the τ min value determines the line address time. Since the Vmin is closely related to a balance of the dielectric biaxiality and spontaneous polarization (Ps),¹²⁾ FLC materials for the τ -Vmin mode need large positive dielectric biaxiality and small or moderate spontaneous polarization, as well as low viscosity in order to obtain fast τ min.

An INAC phase sequence and long helical pitches in nematic and smectic C phases are required in order to yield a high quality of alignment on cooling from the isotropic phase.¹³⁾ In addition, FLC materials require wide temperature range of smectic C phase because it is related to the operating and storage temperature ranges of FLCDs.

A typical FLC material, FDS-2 was developed for the τ -Vmin mode. Its characteristics are shown in **Fig. 2**. This material offers fast τ min value (12 μ sec) and reasonable Vmin value (33V) at 25°C.

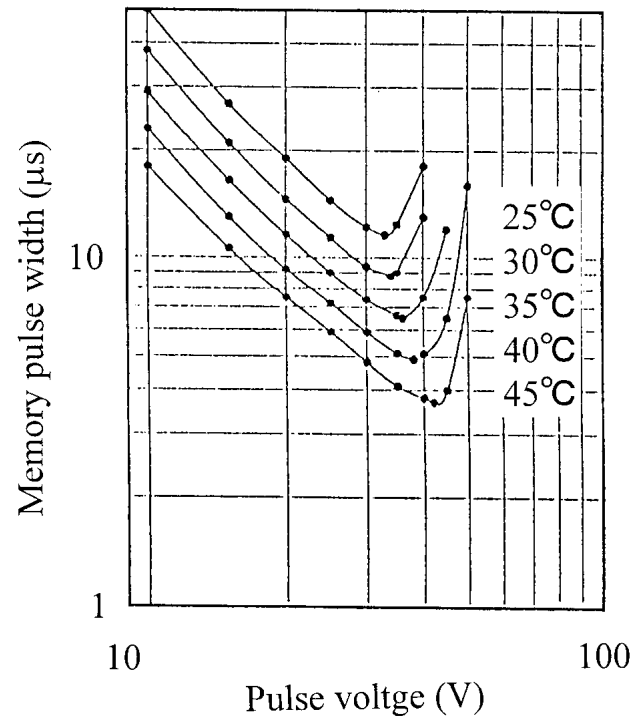

Fig. 2 The characteristic of the developed FLC material FDS-2.

1.2 Device Structure & Molecular Orientation

Shown in **Fig. 3** is the structure of the developed FLCD. On a color filter substrate and a glass substrate with ITO electrodes, there are an insulating film and an aligning films coated. The material of the aligning film was polyimide. The rubbing direction of both substrates is in the same direction (parallel rubbing). An aligning film with a medium pretilt angle (about 3°) was utilized in order to gain 100% of the C2U state without any zigzag defects or any C1 states. The molecular orientation model of the C2U state is illustrated in **Fig. 4**.

Each pixel is divided into two areas with 1:2 ratio so as to realize spatial dither gray scale, as described in the next section. Spacer walls¹⁴⁾ were constructed within the panel in order to show high shock stability. The cell spacing was 1.3 μ m. Optimal adhesion between both substrates was obtained, yielding higher shock stability more than 20kg/cm².¹⁵⁾

1.3 Gray Scale and Addressing

Combining 2-bit spatial dither and 3-bit temporal dither, 64 gray levels for each color were achieved to realize 262,000 colors. The 2-bit spatial dither ratio was one to two (1:2) and 3-bit temporal dither ratio was one to four to sixteen (1:4:16). The driving waveforms are shown in Fig. 5. The duty ratio was 1/480 and the line address time was 23 μ sec/line. The typical values of voltages were $V_s=40V$ and $V_d=7V$.

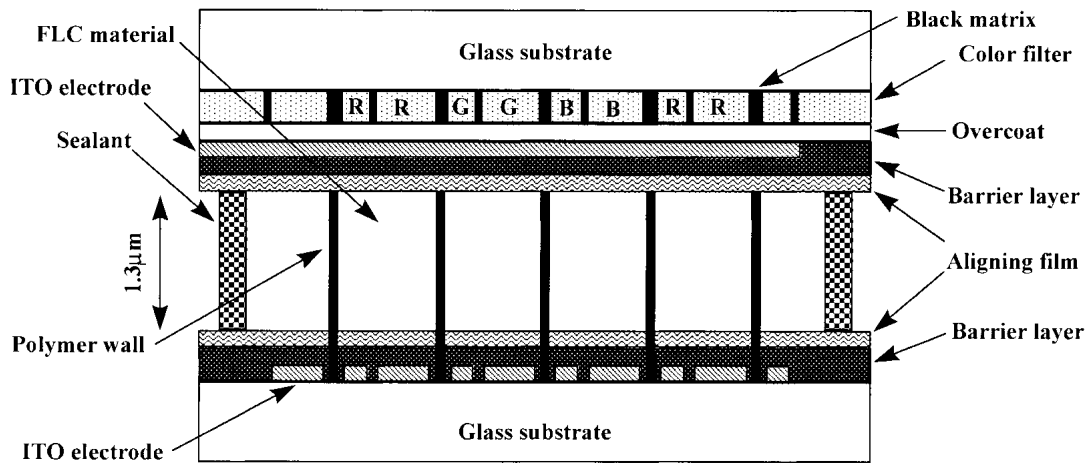

Fig. 3 Device structure of the developed FLC.

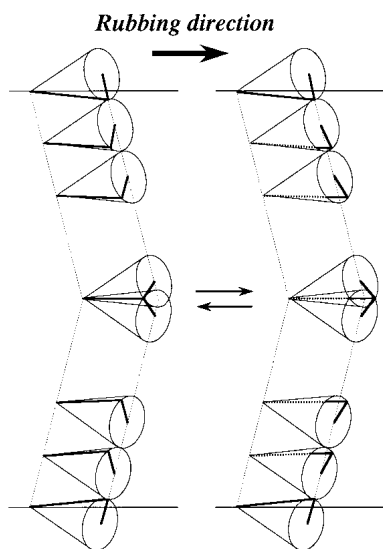

Fig. 4 The C2U orientation.

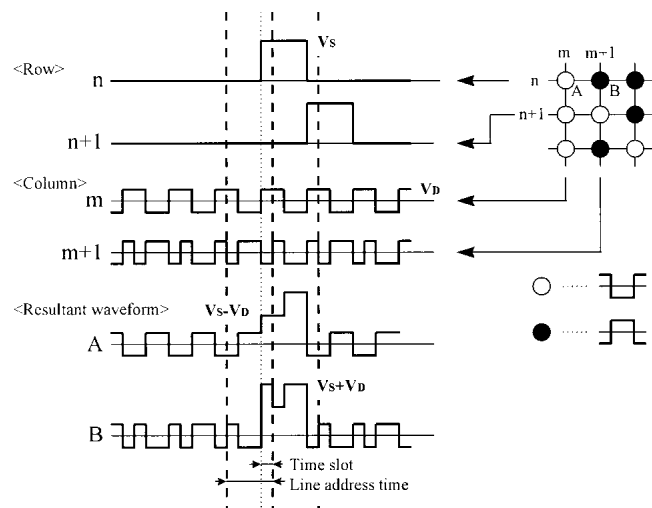

Fig. 5 Drive waveform which is applied in the 6"-prototype FLC.

2. 6-Inch Color FLCDC (Prototype)

A color 6"-prototype FLCDC with 240x320 dots was fabricated, utilizing key technologies described in the above. The main specifications are as follows:

Number of Pixels	240 x 320 dots
Number of Colors	262,000 colors (64 gray levels)
Contrast Ratio	60:1
Shock Stability	20kg/cm ²
Memory Angle	30 degrees

More detailed specifications are summarized in **Table 1**

Conclusion

The development described in this paper has solved two fundamental problems of FLCDC. The one is gray scale and the other is shock stability. Further development is required in order to realize large size FLCDCs with high information content and also to solve the pseudo edge problem, which is induced by digital gray technique as well as PDP.

Acknowledgments

The authors wish to acknowledge contributions from colleagues at Functional Device Laboratories of Sharp, Sharp Laboratories of Europe (SLE) and the Defence Evaluation and Research Agency (DERA).

References

- 1) N. A. Clark and S. T. Lagerwall, Appl. Phys. Lett., 36, 899 (1980).
- 2) Mitsuhiro Koden, Optronics, No.2, 52 (1994).
- 3) M. Koden, Ferroelectrics, 179, 121 (1996).
- 4) M. Koden, H. Katsuse, A. Tagawa, K. Tamai, N. Itoh, S. Miyoshi and T. Wada, Jpn. J. Appl. Phys. 31, 3632 (1992).
- 5) A. Tsuboyama, Y. Hanyu, S. Yoshihara and J. Kanbe, Proc. Japan Display '92, 53 (1992).
- 6) M. Koden, T. Numao, N. Itoh, M. Shiomi, S. Miyoshi and T. Wada, Proc. Japan Display '92, 579 (1992).
- 7) Y. Hanyu, K. Namamura, Y. Hotta, S. Yoshihara and J. Kanbe, SID 93 Digest, 364 (1993).
- 8) H. Mizutani, A. Tsuboyama, Y. Hanyu, S. Okada, M. Terada and K. Katagiri, Abstract of

Table 1 The specifications of the developed 6" color FLCDC.

Display area	6"
Pixel number	240 × 320 (× 3)
Cell thickness	1.3μm
Rubbing	Parallel rubbing
Orientalional state	C2-uniform (C2U)
Shock stability	20kg/cm ²
Drive voltage	V _s =40V, V _d =7V
Line address time	23μs/line
Duty ratio	1/480
Frequency	60Hz
Contrast ratio	60:1
Gray scale	64 gray levels
Color	262,000 colors

FLC'97, 66 (1997).

- 9) P. W. H. Surguy, P. J. Ayliffe, M. J. Birch, M. F. Bone, I. Coulson, W. A. Crossland, J. R. Hughes, P. W. Ross, F. C. Saunders and M. J. Towler, *Ferroelectrics*, 122, 63 (1991).
- 10) M. Koden, H. Katsuse, N. Itoh, T. Kaneko, K. Tamai, H. Takeda, M. Kido, M. Matsuki, S. Miyoshi and T. Wada, *Ferroelectrics*, 149, 183 (1993).
- 11) J. R. Hughes and E. P. Raynes, *Liq. Cryst.*, 13, 597 (1993).
- 12) M. J. Towler, J. C. Jones and E. P. Raynes, *Liq. Cryst.*, 11, 365 (1992).
- 13) M. J. Bradshaw, V. Brimmell and E. P. Raynes, *Liq. Cryst.*, 2, 107 (1987).
- 14) S. R. Lee, O. K. Kwon, S. H. Kim and S. J. Choi, *SID 97 Digest*, 1051(1997).
- 15) P. A. Gass, M. J. Towler, M. Shigeta, K. Tamai, H. Uchida, P. E. Dunn, S. D. Haslam and J. C. Jones, *Proc. IDRC*, L-28 (1997).

(Received Sept. 17, 1997)